

IRENEUSZ JABŁOŃSKI, JANUSZ MROCZKA

Wroclaw University of Technology
Chair of Electronic and Photonic Metrology
Poland, e-mail: ireneusz.jablonski@pwr.wroc.pl

INTERRUPTER VALVE KINEMATICS IN THE ISSUES OF PARAMETER ESTIMATION OF THE RESPIRATORY SYSTEM MODEL

The latest papers have been suggesting that the dynamics of transient state should be taken into account as the phenomena which occur in a respiratory system are interpreted (quantitatively and qualitatively). The influence of geometry and closure valve characteristic on the precision of obtained estimators of its parameters has been analyzed in the paper for the chosen model structure of the system. Results of simulation studies show that minimalization of mean-squared uncertainty d_{MSE} of the model elements estimation is obtained as valve closing (opening) time is shortened and its complete closure time is extended so that a linear increase in pressure P_{ao} is included.

Keywords: pulmonary mechanics, interrupter technique, indirect measurement, valve characteristics

1. INTRODUCTION

Watching out for the importance of the respiratory system in the context of the whole human organism's function and the wide spectrum of the identified pathologies, simultaneously, the need for working out effective diagnostic and predictive methods appears as a vital thread of research work. Utilitarian conditions, i.e. test invasiveness limitation, its procedural simplification or cheap and reliable hardware construction are of great importance in this case. The latest papers [1–4] have been suggesting that the dynamics of transient state should be taken into account as the phenomena which occur in a respiratory system are interpreted (quantitatively and qualitatively). Amongst many algorithms dedicated to the respiratory mechanics evaluation [5–9], the airflow interrupter technique (IT) is characterized by numerous advantages. The original idea postulated by von Neergard and Wirtz [10] consisted in short-term airflow interruption by valve closure at the patient's mouth and simultaneous measurement of flow rate (Q_{ao}) falling to zero and rising pressure (P_{ao}) in the mouthpiece. The index determined in this way – interrupter resistance $R_{int} = \Delta P_{ao}/Q_{ao}$ – was interpreted as a measure of airways resistance R_{aw} , which in the progress of evolutionary work turned out to be a source of inaccuracy, first of all because of the nontrivial character of acquired data (P_{ao} signal, especially), reflecting the rich nature of the phenomena accompanying

occlusional manoeuvres in the respiratory system. As shown in introductory reports [11, 12, 3], the characteristics of the interrupter device used during the measurements highly harmonize with the concrete manifested processes, thereby determining the diagnostic insight of the designed measurement method.

Conceptions initiated by the authors on a modified version of the interrupter technique – [13–15] – the enhanced interrupter technique (EIT), apart from the above-mentioned arguments, need an investigation of the geometry and the influence of the operating characteristics of the interrupter valve on the resultant quality of parameter estimation in the suggested metrological model of the respiratory system, also for the sake of proposed methodology of the indirect measurement. Relying on earlier results [13, 14], research presented in the paper concentrates on the post-interrupter data analysis only in the time domain. However, from the work of Romero *et al.* [12] and Frey *et al.* [3, 16] it can be concluded that the importance of investigated issues also for the frequency algorithms, favourably augurs the possibility to expand IT insight at least to the level of FOT. From the application point of view, the reported results can be a symptomatic source element for a proposal to construct a competitive portable device dedicated to respiratory mechanics measurements, exploiting the time, frequency or joined time-frequency regime of post-interrupter data analysis.

2. METHODS

2.1. Electrical replacement model for the respiratory system during airflow interruption

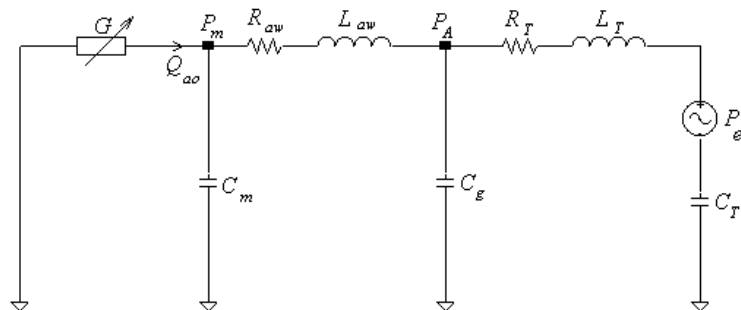

Fig. 1. Electrical replacement model of the respiratory system during airflow interruption: G – conductance of the valve-transducer unit, C_m – upper airway compliance, R_{aw} and L_{aw} – resistance and inertance of the airways, C_g – alveolar gas compliance, R_T , L_T and C_T – resistance, inertance and compliance of lung tissue and chest wall, P_e – source adequate to respiratory muscle activity, P_A – alveolar pressure, P_m – mouth pressure.

The research was conducted on the basis of simulation experiments which used the analog proposed by DuBois (Fig. 1) [6] (earlier suggested by Mead and Whittenberger [17]), in which additionally upper airway compliance C_m and conductance G were included, reflecting the changes of the valve-transducer unit conductance. Values of the parameters were fixed accordingly to the circuit investigated in [4, 18].

The presented works use the methodology of the forward-inverse modeling [19].

2.2. Model of the valve-transducer unit

Description of the experiments using various structural solutions of the valve can be found in literature [1, 20, 21, 22], the most popular of which are presented in Fig. 2. Applying the different characteristics of their operation is a question of great importance (Table 1), while the relation between the closing (opening) time and the duration time of the complete closure of the valve and the precision of obtained parameter estimators have not been pointed out.

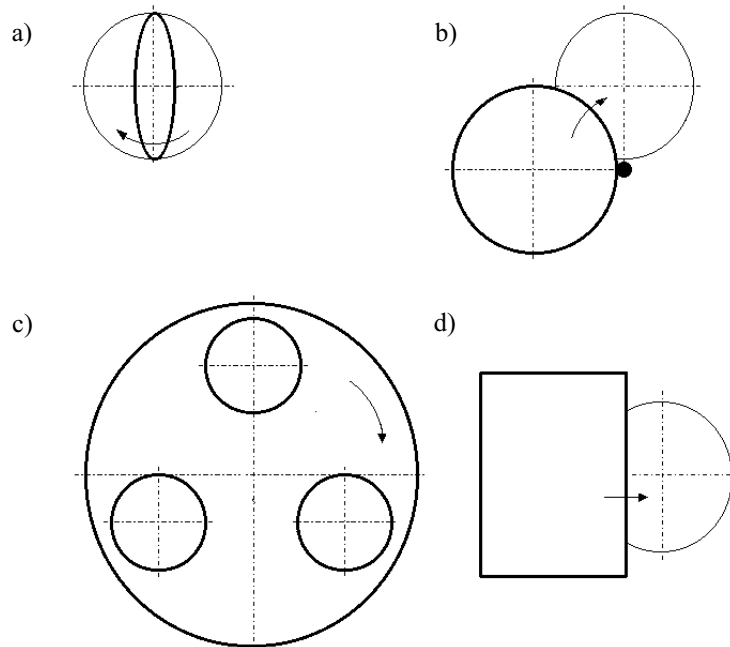

Fig. 2. Ways of airflow limitation at the airways opening: a) shutter-type valve, b) off-centre latch, c) rotating disc, d) axial latch.

Table 1. Characteristics of interrupter devices described in literature; MV – mechanical ventilation, SB – spontaneous breathing, CS – computer simulation, PMT – pneumotachograf.

Author, year (reference number)	Application	Valve type/Drive	Closing time	Time closed/ Duration time	Type of occlusion
Clements <i>et al.</i> , 1959 (23)	MV, SB	Rotary valve, rotation at constant frequency	< 50 ms	Equal intervals	10 times/s
Knudson <i>et al.</i> , 1974 (24)	SB	Manual Electromagnetic	10 ms 30 ms		Single Repetitive
Clarke <i>et al.</i> , 1982 (20)	SB	Two rotating discs	1 ms	100 ms	Repetitive (every 500 ms)
Gottfried <i>et al.</i> , 1985 (25)	MV	Pneumatical shutter		100–200 ms	Single
Bates <i>et al.</i> , 1987 (26)	CS	Electromagnetic	12 ms		
Bates <i>et al.</i> , 1989 (27)	Animals	Electromagnetic	15 ms	Variable	Repetitive
Liistro <i>et al.</i> , 1989 (28)	SB	Pneumatic	6–7 ms	100 ms	Repetitive
Vooren and Van Zoomeren, 1989 (29)	SB	Electromagnetic	5 ms	150 ms-4s	Single
Chowienczyk <i>et al.</i> , 1991 (30)	SB	Plate driven by servomotor	5 ms	100 ms	Single
Fletcher <i>et al.</i> , 1992 (31)	SB, pediatrics	Manual	< 30 ms	Variable, manually operated	Repetitive (6–7/s)
Hultsch and Lipowsky, 1992 (32)	MV, pediatrics	Electrical	10 ms	100 ms-1s	Single
Smith <i>et al.</i> , 1992 (33)	MV, animals	Electromagnetic	5–6 ms	40 ms (variable)	Repetitive
Freezer <i>et al.</i> , 1993 (21)	MV, pediatrics		12 ms	100–500 ms (opening shutter)	Repetitive
Phagoo <i>et al.</i> , 1993 (34)	SB	Elliptical metal plate driven by servomotor	5–6 ms	100 ms	Single
Van Altena and Gimeno, 1994 (35)	SB	Jaeger pneumoscope	5 ms	100 ms	Single
Carter <i>et al.</i> , 1994 (36)	SB, pediatrics	Two rotating discs, rotation at constant frequency	12 ms	100 ms	Repetitive (3/s)
Frey and Kraemer, 1995 (37)	SB, pediatrics	Jaeger bronchoscreen	15 ms	100 ms	Single
Frey <i>et al.</i> , 1997 (3)	SB	Rotating blade driven by stepper motor	1 ms	14.5 ms	Repetitive
Oswald-Mammosser <i>et al.</i> , 1997 (22)	SB, pediatrics	Electromagnetic	4 ms	100 ms	Single in inspiration and expiration

The paper presents the electrical analog of the valve-transducer unit consisting of a series combination of constant transducer resistance R_p and a time-varying valve

resistance R_v . The value $R_p = 98 \text{ Pa}\cdot\text{s}\cdot\text{dm}^{-3}$ was calculated with Poiseuille's equation, which defines flow resistance through the cylindrical tube [38], whereas R_v , also in accordance with the foregoing law, was fixed as inversely proportional to the square of the effective cross-section area S of the tube, suitable for the geometry and constructional solution of the valve:

$$S = S_c - S_v, \tag{1}$$

where: S – effective cross-section area of the tube, S_c – cross-section area of the tube, S_v – area delimited by the shape of the closed valve, defined in the plane perpendicular to the longitudinal axis of symmetry of the tube.

In the case of a valve with circular rotational surface limiting the flow (Fig. 3a), placed symmetrically in the tube, time changes of R_v are described by the relationship

$$R_v = \frac{k(l)}{\pi^2 r^4 \left[1 - \sin\left(\frac{2\pi}{T}t\right)\right]^2}, \tag{2}$$

where: $k(l)$ – coefficient proportional to the length, r – valve radius, T – valve turning period, t – time.

Diameter of the considered valve $d = 25 \text{ mm}$, and $k(l)/\pi^2 r^4$ was set to $5.9 \text{ Pa}\cdot\text{s}\cdot\text{dm}^{-3}$.

Therefore, the total resistance of the valve-transducer unit is equal to

$$R = R_p + R_v \tag{3}$$

and its conductance

$$G = 1/R. \tag{4}$$

Example changes of conductance as a function of time were presented in Fig. 3b.

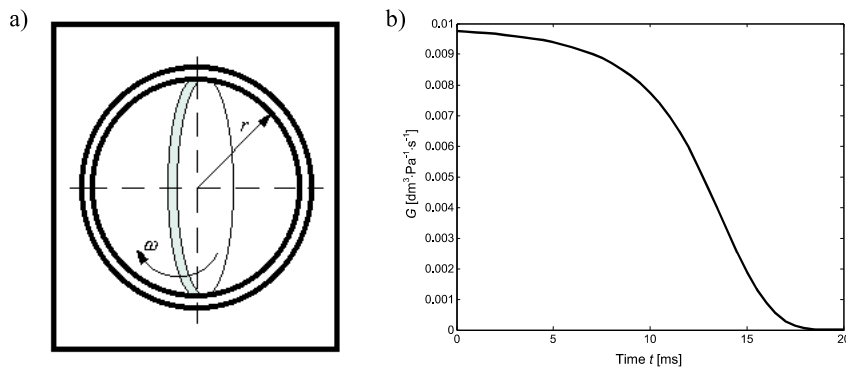

Fig. 3. a) Valve construction (frontal view), b) changes of conductance G during the valve closing (closing time $t_c = 20 \text{ ms}$).

2.3. Model identification

Parameter estimation of the model was carried out in the time domain for various operational conditions of the valve; it is consistent with the suggestions expressed in [4], that this regime assures more reliable evaluation of the post-interrupter data.

In the case of the mathematical model formulated in state-space, the above-mentioned procedure consisted in fitting the signal $\mathbf{y} = [\mathbf{q}_1^T, \mathbf{p}^T, \mathbf{q}_2^T]^T$ from the model output to the signal $\mathbf{z} = [\mathbf{q}_{z1}^T, \mathbf{p}_z^T, \mathbf{q}_{z2}^T]^T$ measured in the real system (Fig. 4), where: $\mathbf{q}_1, \mathbf{q}_{z1}$ – flows at the airway opening in a range $t_0 \dots t_1$, \mathbf{p}, \mathbf{p}_z – pressures at the airway opening acquired between $t_1 \dots t_2$, $\mathbf{q}_2, \mathbf{q}_{z2}$ – flows at the airway opening in a range $t_2 \dots t_3$. Passive expiration was assumed during research, which made results independent of inspiration muscle driving pressure. Hence, introduction of the additional parameter $P_0 = P_{C_i}(t_0)$ is sufficient. Assuming uncorrelated additive Gaussian noise, for the maximum likelihood method, the identification of the respiratory system model boiled down to the application of the iterative algorithm of parameter estimation in order to minimize the criterion function:

$$V(\boldsymbol{\theta}) = (\mathbf{q}_{z1} - \mathbf{q}_1)^T \mathbf{R}_q (\mathbf{q}_{z1} - \mathbf{q}_1) + (\mathbf{p}_z - \mathbf{p})^T \mathbf{R}_p (\mathbf{p}_z - \mathbf{p}) + (\mathbf{q}_{z2} - \mathbf{q}_2)^T \mathbf{R}_q (\mathbf{q}_{z2} - \mathbf{q}_2), \quad (5)$$

where $\boldsymbol{\theta} = [C_m, R_{aw}, L_{aw}, C_g, R_t, L_t, C_t, P_0]$ is an unknown parameters vector and $\mathbf{R}_q, \mathbf{R}_p$ represents the covariant matrix of flow and pressure signal disturbances, respectively.

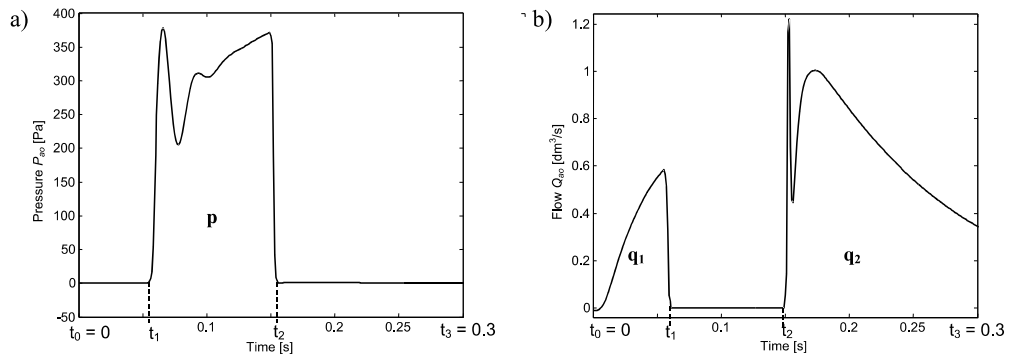

Fig. 4. Pressure P_{ao} (a) and flow Q_{ao} (b) signals at the airway opening used in the procedure of parameter estimation of the respiratory system model.

2.4. Variance analysis of the estimators

Time-domain identification of the proposed model of the respiratory system during airflow interruption needs applying the iterative algorithms. The result of their application is the vector of parameter estimators $\hat{\boldsymbol{\theta}}$ and the estimator of their variances $\boldsymbol{\Sigma}$:

$$\boldsymbol{\Sigma}(\hat{\boldsymbol{\theta}}) = [\boldsymbol{\eta}^T(\hat{\boldsymbol{\theta}}) \mathbf{R}^{-1} \boldsymbol{\eta}(\hat{\boldsymbol{\theta}})]^{-1}, \quad (6)$$

where $\boldsymbol{\eta}$ is a sensitivity matrix of the output \mathbf{y} of the model in relation to the parameters:

$$\boldsymbol{\eta} = \frac{\partial \mathbf{y}}{\partial \boldsymbol{\theta}}. \quad (7)$$

For various reasons, it is more comfortable to assess the variance of the estimators before creating the identification algorithm. The approach proposed in the paper of the forward-inverse modelling has the advantage that we know both the structure of the model and the chosen vector of parameters $\boldsymbol{\theta}_0$ of the forward model representing the real system. Since $\hat{\boldsymbol{\theta}} \approx \boldsymbol{\theta}_0$ is the effect of work of the identification procedure, we can assess the variance of the obtained estimators as $\boldsymbol{\Sigma}(\boldsymbol{\theta}_0)$. Then, we can calculate the vector of relative uncertainties of estimation $\mathbf{d} = [d_1, d_2, \dots, d_p]$, defined as standard deviations to the real values of the parameters ratio, as follows:

$$\mathbf{d} = \boldsymbol{\theta}_0^{-1} \text{diag}(\boldsymbol{\Sigma}(\boldsymbol{\theta}_0))^{1/2}, \quad (8)$$

where $\boldsymbol{\theta}_0 = \text{diag}(\boldsymbol{\theta}_0)$.

A measure of quality fitting of the model to the real respiratory system, for defined, subsequent values of valve closing (opening) time and its complete closure time, can be the relative mean-square error of estimation:

$$d_{MSE} = \sqrt{\frac{1}{p} (d_1^2 + \dots + d_p^2)}, \quad (9)$$

where p is the number of parameters.

3. RESULTS

Single-time airflow interruption with duration time $t_2 - t_1 = 50, 75, 100, 150$ ms and various speed of valve opening (closing) $t_c = t_o = 1, 5, 10, 15, 20$ ms was simulated (Fig. 5) in the circuit described in section 2.1. In each case occlusion was initiated at $t_1 = 70$ ms from the start of expiration. Data were sampled at 1 kHz. Then, Gaussian noise with standard deviation $\sigma_p = 1$ Ps and $\sigma_q = 0.01$ dm³s⁻¹ was added to pressure and flow signals. Hence, $\mathbf{R}_p = \sigma_p^2 \mathbf{I}$ and $\mathbf{R}_q = \sigma_q^2 \mathbf{I}$, appropriately.

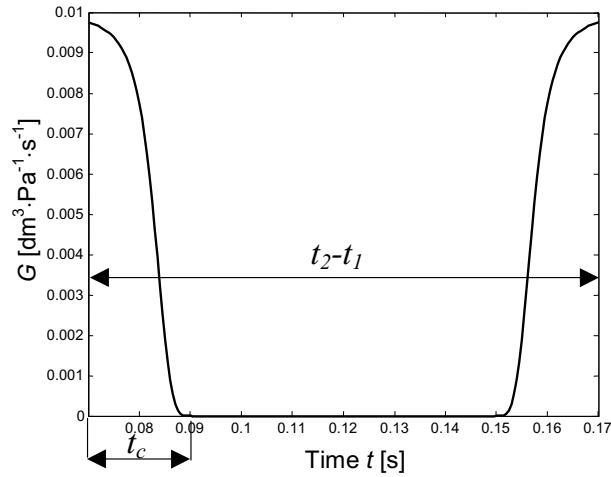

Fig. 5. Simulation of the interrupter valve characteristics.

Modifying the values of each element θ_k of parameters vector $\boldsymbol{\theta}_0$ by $\pm\Delta\theta_k = 0.1 \cdot \theta_k$, the sensitivity vectors for the model were calculated numerically:

$$\eta_k = \frac{\partial y}{\partial \theta_k} \approx \frac{\mathbf{y}(\theta_k + \Delta\theta_k) - \mathbf{y}(\theta_k - \Delta\theta_k)}{2\Delta\theta_k}. \quad (10)$$

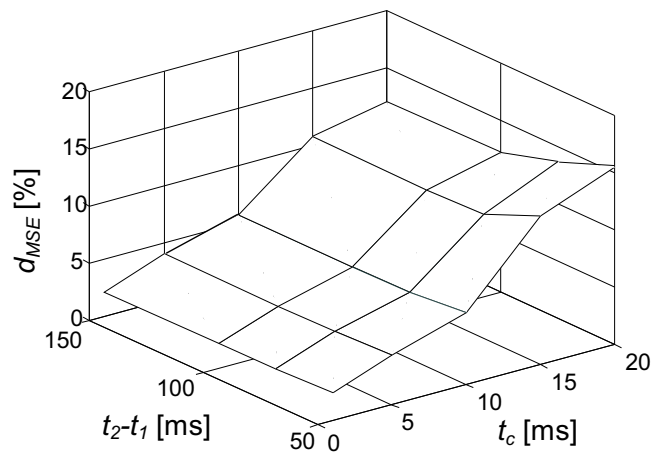

Fig. 6. Time of interruption influence on the precision of parameter estimation of the respiratory system model.

Using Eq. (8), relative uncertainty of parameters estimation of respiratory system model was evaluated for suggested time of occlusion duration ($t_2 - t_1$) and closing time

t_c . Next, on the basis of (9), the mean-squared value of these quantities was determined. The obtained results are presented graphically in Fig. 6.

4. DISCUSSION AND SUMMARY

The research presented in the paper, aimed at obtaining, by computer simulation, the influence of valve closing (opening) time and time of its complete closure on parameter estimation accuracy of the respiratory system model, gives the possibility to match optimal conditions for valve operation with measurement of mechanical properties of the real system. It is especially important when there are accessible numerous descriptions in literature of experiments which use various construction of the valves limiting airflow with a wide range of their closing time (1–20 ms) [39, 40, 16, 28, 41].

The aim was realized by the time-domain evaluation of parameter estimation quality of the model, which consisted in fitting the signal from the model output and the real system, formulated by combination in the proper ranges the time courses of flow (Q_{ao}) and pressure (P_{ao}) at the airway opening. The basis to determine identification properties of the respiratory system model was the calculation of its sensitivity matrix for the true parameter vector and variance evaluation of estimator vector for the assumed character of noise in acquired pressure and flow signals. The measure of fitting quality of the model to the real system, for the consecutive, defined values of valve closing time and the time of its complete closure, was the mean squared relative estimation uncertainty d_{MSE} .

The results suggest that making occlusion as quick as possible, including both transient state and slow linear rise of P_{ao} in its duration time, is conducive to increasing the estimation accuracy of the investigated system. In practice, it is difficult to obtain t_c in the order of 1 ms, thus using valves with 5–10 ms closing time is recommended. As is the case in Fig. 6, d_{MSE} suddenly increases above this value. Research proved that taking exclusively the part of P_{ao} with rapid increase and accompanying damped oscillations into the identification process does not guarantee reliable parameter estimators of the respiratory system model. It can result from the fact that the aforementioned range of changes of the investigated quantity first of all contains information on reactant (compliances, inertances) properties of the system, while the part with slow rise of P_{ao} , needed to decrease d_{MSE} , to a large degree reflects its resistive character. Therefore, evaluation accuracy of the real respiratory system properties on the basis of parameter estimators of its model is conditioned by complementarity of phenomena taking part in the identification process, accessible in the proper prepared data.

In the future, it is worth to analyze the influence of various structural solutions of valves on results obtained during the model identification of the respiratory system. Because of problems with matrix $\boldsymbol{\eta}^T \mathbf{R}^{-1} \boldsymbol{\eta}$ inversion, where $\mathbf{R} = \text{diag}(\mathbf{R}_q, \mathbf{R}_p, \mathbf{R}_q)$, which can be a source of additional inaccuracies during estimation, it is necessary to think about reduction of that error by applying a regularization procedure.

Significance of results can spread over future, evolutionary versions of the EIT algorithm, including the problem of data analysis in the time and the frequency domains. As results from the works of Frey *et al.* [3, 16], excitation used in the IT technique has numerous advantages in relation to many popular, frequency algorithms of evaluation of the respiratory mechanics. The version with the valve characterized by closing time ~ 1 ms (HIT) in the introductory way implies new diagnostic abilities and hardware simplifications which, being correlated to the investigations presented in the paper, guides future developmental work in the discussed area.

REFERENCES

1. Frey U., Kraemer R.: *Interrelationship between postocclusional oscillatory pressure transients and standard lung function in healthy and asthmatic children*. *Pediatr. Pulmonol.*, vol. 19, no. 6, pp. 379–388, 1995.
2. Frey U., Schibler A., Kraemer R.: *Pressure oscillations after flow interruption in relation to lung mechanics*. *Respir. Physiol.*, vol. 102, no. 2–3, pp. 225–237, 1995.
3. Frey U., Suki B., Kraemer R., Jackson A. C.: *Human respiratory input impedance between 32 and 800 Hz measured by interrupter technique and forced oscillations*. *J. Appl. Physiol.*, vol. 82, no. 3, pp. 1018–1023, 1997.
4. Jabłoński I., Polak A. G., Mroczka J.: *Methods of identification of a model for the respiratory system during airflow interruption*. *PAK*, vol. 8, pp. 18–22, 2000. (in Polish)
5. Bates J. H. T., Baconnier P., Milic-Emili J.: *A theoretical analysis of interrupter technique for measuring respiratory mechanics*. *J. Appl. Physiol.*, vol. 64, no. 5, pp. 2204–2214, 1988.
6. DuBois A. B., Brody A. W., Lewis D. H., Burgess B. F. Jr.: *Oscillation mechanics of lungs and chest in man*. *J. Appl. Physiol.*, vol. 8, no. 6, pp. 587–594, 1956.
7. Lutchen K. R., Yang K., Kaczka D. W., Suki B.: *Optimal ventilator waveform for estimating low frequency mechanical impedance*. *J. Appl. Physiol.*, vol. 75, no. 1, pp. 478–488, 1993.
8. Tantucci C., Duguet A., Ferreti A., Mehiri S., Arnulf I., Zelter M., Similowski T., Derenne J-P., Milic-Emili J.: *Effect of negative expiratory pressure on respiratory system flow resistance in awake snorers and nonsnorers*. *J. Appl. Physiol.*, vol. 87, no. 3, pp. 969–976, 1999.
9. Schmidt M., Foitzik B., Hochmuth O., Schmalisch G.: *In vitro investigations of jet-pulses for the measurement of respiratory impedance in newborns*. *Eur. Respir. J.*, vol. 14, no. 5, pp. 1156–1162, 1999.
10. Neergaard J. von, Wirz K.: *Die Messung der Strömungswiderstände in den Atemwegen des Menschen, insbesondere bei Astma und Emphysem*. *Z. Klin. Med.*, vol. 105, pp. 51–82, 1927.
11. Kessler V., Mols G., Bernhard H., Haberthür C., Guttmann J.: *Interrupter airway and tissue resistance: errors caused by valve properties and respiratory system compliance*. *J. Appl. Physiol.*, vol. 87, no. 4, pp. 1546–1554, 1999.
12. Romero P. V., Sato J., Shardonofsky F., Bates J. H. T.: *High frequency characteristics of respiratory mechanics determined by flow interruption*. *J. Appl. Physiol.*, vol. 69, no. 5, pp. 1682–1688, 1990.
13. Jabłoński I.: *Metrological analysis of the airflow interrupter technique in the respiratory system properties investigations*. PhD thesis, Wrocław, 2004. (in Polish)
14. Jabłoński I., Mroczka J.: *Computer-aided evaluation of a new interrupter algorithm in respiratory mechanics measurement*. *Biocyb. & Biomed. Eng.*, vol. 26, no. 3, pp. 33–47, 2006.
15. Jabłoński I., Mroczka J.: *A station for the respiratory mechanics measurement by occlusion techniques*. *Metrol. & Meas. Syst.*, vol. 14, no. 2, pp. 229–240, 2007.

16. Frey U., Silverman M., Kraemer R., Jackson A. C.: *High-frequency respiratory input impedance measurements in infants assessed by the high speed interrupter technique*. Eur. Respir. J., vol. 12, no. 1, pp. 148–158, 1998.
17. Mead J., Whittenberger J. L.: *Evaluation of airway interruption technique as a method for measuring pulmonary air-flow resistance*. J. Appl. Physiol., vol. 6, no. 7, pp. 408–416, 1954.
18. Lutchen K. R., Jackson A. C.: *Confidence bounds on respiratory mechanical properties estimated from transfer versus input impedance in humans versus dogs*. IEEE Trans. Biomed. Eng., vol. 39, no. 6, pp. 644–651, 1992.
19. Lutchen K. R., Costa K. D.: *Physiological interpretations based on lumped element models fit to respiratory impedance data: use of forward-inverse modeling*. IEEE Trans. Biomed. Eng., vol. 37, no. 11, pp. 1076–1085, 1990.
20. Clarke J. R., Jaeger M. J., Zumrick J. L., O'Bryan R., Spaur W. H.: *Respiratory resistance from 1 to 46 ATA measured with the interrupter technique*. J. Appl. Physiol., vol. 52, no. 3, pp. 549–555, 1982.
21. Freezer N. J., Lanteri C. J., Sly P. D.: *Effect of pulmonary blood flow on measurements of respiratory mechanics using the interrupter technique*. J. Appl. Physiol., vol. 74, no. 3, pp. 1083–1088, 1993.
22. Oswald-Mammosser M., Llerena C., Speich J. P., Donato L., Lonsdorfer J.: *Measurements of respiratory system resistance by the interrupter technique in healthy and asthmatic children*. Pediatr. Pulmonol., vol. 24, no. 2, pp. 78–85, 1997.
23. Clements J. A., Sharp J. T., Johnson R. P., Elam J. O.: *Estimation of pulmonary resistance by repetitive interruption of airflow*. J. Clin. Invest., vol. 38, no. 7, pp. 1262–1270, 1959.
24. Knudson R. J., Mead J., Knudson D. E.: *Contribution of airway collapse to supramaximal expiratory flows*. J. Appl. Physiol., vol. 36, no. 6, pp. 264–268, 1974.
25. Gottfried S. B., Rossi A., Higgs B. D., Calverley P. M. A., Zocchi L., Bozic C., Milic-Emili J.: *Noninvasive determination of respiratory system mechanics during mechanical ventilation for acute respiratory failure*. Am. Rev. Respir. Dis., vol. 131, no. 3, pp. 414–420, 1985.
26. Bates J. H. T., Hunter I. W., Sly P. D., Okubo S., Filialtrault S., Milic-Emili J.: *Effect of valve closure time on determination of respiratory resistance by flow interruption*. Med. Biol. Eng. Comput., vol. 25, no. 2, pp. 136–140, 1987.
27. Bates J. H. T., Brown K. A., Kochi T.: *Respiratory mechanics in the normal dog determined by expiratory flow interruption*. J. Appl. Physiol., vol. 67, no. 6, pp. 2276–2285, 1989.
28. Liistro G., Stănescu D., Rodenstein D., Veriter C.: *Reassessment of the interruption technique for measuring flow resistance in humans*. J. Appl. Physiol., vol. 67, no. 3, pp. 933–937, 1989.
29. Vooren P. H., Zomeran Van B. C.: *Reference values of total respiratory resistance, determined with the "opening" interruption technique*. Eur. Respir. J., vol. 2, no. 10, pp. 966–971, 1989.
30. Chowienzyk P. J., Lawson C. P., Lane S. Johnson R., Wilson N., Silverman M., Cochrane G. M.: *A flow interruption device for measurement of airway resistance*. Eur. Respir. J., vol. 4, no. 5, pp. 623–628, 1991.
31. Fletcher M. E., Dezateux C. A., Stocks J.: *Respiratory compliance in infants – a preliminary evaluation of the multiple interrupter technique*. Pediatr. Pulmonol., vol. 14, no. 2, pp. 118–125, 1992.
32. Hultzsck W., Lipowsky G.: *Intrapulmonale Druckmessungen bei Hochfrequenzbeatmung extrem kleiner Frühgeborener*. Monatsschr. Kinderheilkd., vol. 140, pp. 476–482, 1992.
33. Smith P. G., Falahat A., Carlo W. A.: *Measurement of interrupter resistance in rabbits exposed to methacholine aerosols*. J. Appl. Physiol., vol. 72, no. 6, pp. 2454–2457, 1992.
34. Phagoo S. B., Watson R. A., Pride N. B., Silverman M.: *Accuracy and sensitivity of the interrupter technique for measuring the response to bronchial challenge in normal subjects*. Eur. Respir. J., vol. 6, no. 7, pp. 996–1003, 1993.
35. Altena Van R., Gimeno F.: *Respiratory resistance measured by flow-interruption in a normal population*. Respiration, vol. 61, no. 5, pp. 249–254, 1994.

36. Carter E. R., Stacenko A. A., Pollock B. H., Jaeger M. J.: *Evaluation of the interrupter technique for the use of assessing airway obstruction in children*. *Pediatr. Pulmonol.*, vol. 17, no. 4, pp. 211–217, 1994.
37. Frey U., Kraemer R.: *Interrelationship between postocclusional oscillatory pressure transients and standard lung function in healthy and asthmatic children*. *Pediatr. Pulmonol.*, vol. 19, no. 6, pp. 379–388, 1995.
38. Ginzburg I., Elad D.: *Dynamic model of the bronchial tree*. *J. Biomed. Eng.*, vol. 15, no. 4, pp. 283–288, 1993.
39. Bates J. H. T., Abe T., Romero P. V., Sato J.: *Measurement of alveolar pressure in closed-chest dogs during flow interruption*. *J. Appl. Physiol.*, vol. 67, no. 1, pp. 488–492, 1989.
40. Frey U., Kraemer R.: *Oscillatory pressure transients after flow interruption during bronchial challenge test in children*. *Eur. Respir. J.*, vol. 10, no. 1, pp. 75–81, 1997.
41. Phagoo S. B., Wilson N. M., Silverman M.: *Evaluation of a new interrupter device for measuring bronchial responsiveness and response to bronchodilator in 3 year old children*. *Eur. Respir. J.*, vol. 9, no. 7, pp. 1374–1380, 1996.